

INSTRUCTIONS

PLEASE READ CAREFULLY BEFORE USING PROJECTOR

You are now the proud possessor of a real Cinema showing real MOVING PICTURES with standard 8mm. film. Like all cinematograph projectors it is a precision instrument, and you cannot hope for best results unless you operate it properly. Please read the following instructions carefully before attempting to use your projector, and ask your parents to explain anything you do not understand. You will then enjoy being able to entertain your friends with your collection of films.

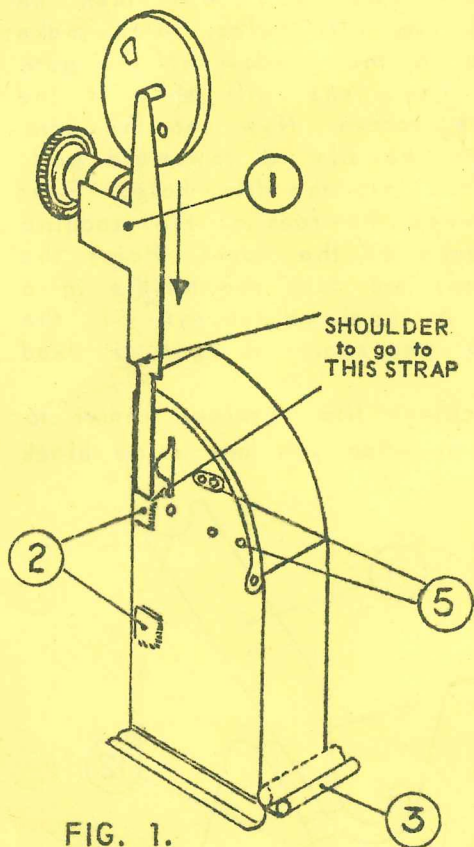

FIG. 1.

(A) TO ASSEMBLE THE MACHINE

Slide the combined lens and spoolholder bracket (1) under the two straps in the body (2). Make sure it is in as far as the shoulder.

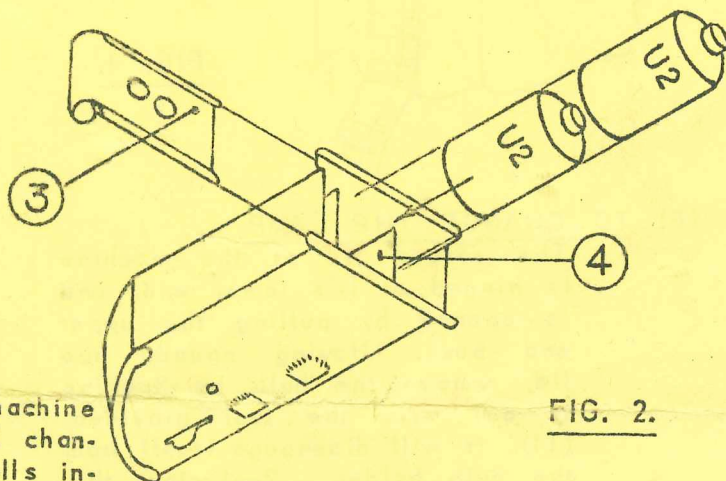

FIG. 2.

(B) TO INSERT BATTERY

Slide out the base of the machine (3) you will see inside a metal channel (4) Put two No.U.2. Dry cells into this channel, one behind the other, with the central contact pointing towards you. - That is the opposite way to which the batteries are usually put in electric torches. **THIS IS MOST IMPORTANT**, otherwise the switch will not work. Now slide the base back. The lamp should then switch OFF when the base is pushed right in, and switch ON when the base is pulled out about 1/2 inch. To operate from mains supply - connect transformer leads to sockets (5). (See FIG 1).

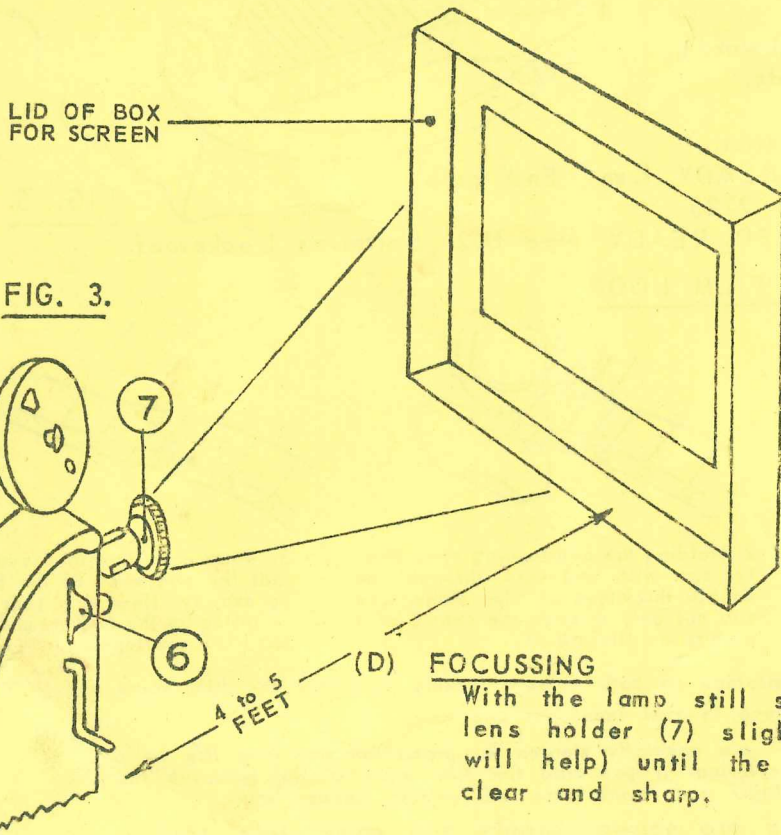

FIG. 3.

(C) ADJUSTING THE LAMP

Stand the screen up 4 to 5 feet from the projector and switch on the light. Then by using the lamp adjuster (6), move the bulb in all directions until you obtain a brilliantly illuminated rectangle where the picture is going to be. This adjustment is essential for good pictures.

(D) FOCUSING

With the lamp still switched on, move the plastic lens holder (7) slightly in and out (twisting it will help) until the edges of the rectangle are clear and sharp.

CONTINUED OVERLEAF

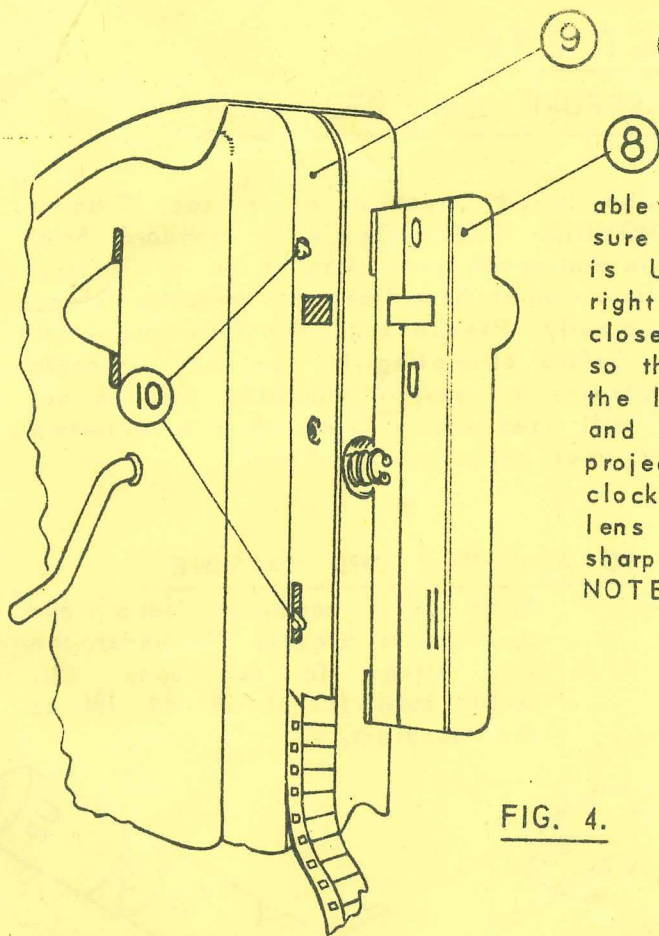

(3) TO INSERT THE FILM

Hold the gate (8) open and lay the film in track (9) with the holes in the film away from the gate hinge. The two claws (10), will then be able to engage with the film holes. Also make sure that the picture in the window of the gate is UPSIDE DOWN. The lens will show it the right way up on the screen. Now let the gate close and gently give the film a downward pull, so that the claws click into the film holes. Pass the loop of film between the feet of the machine and between the cheeks of the spool. Point the projector at the screen, and turn the handle in a clockwise direction. A final adjustment of the lens holder may be necessary to get a dead sharp picture.

NOTE:- When using colour film, project nearer to the screen than when you are using black and white.

FIG. 4.

(F) TO CHANGE THE LAMP

The curved lid of the machine is hinged at its lower end, and is opened by pulling the upper end back. Having opened the lid, remove the bulb by hooking it out with the tool provided. (11). It will disengage itself from the bulb holder. Replacing the new bulb is easily done by pushing it gently down with the other end of the tool. Now move the bulb adjuster (6) about, so that the nose of the bulb finds its correct seating (12).

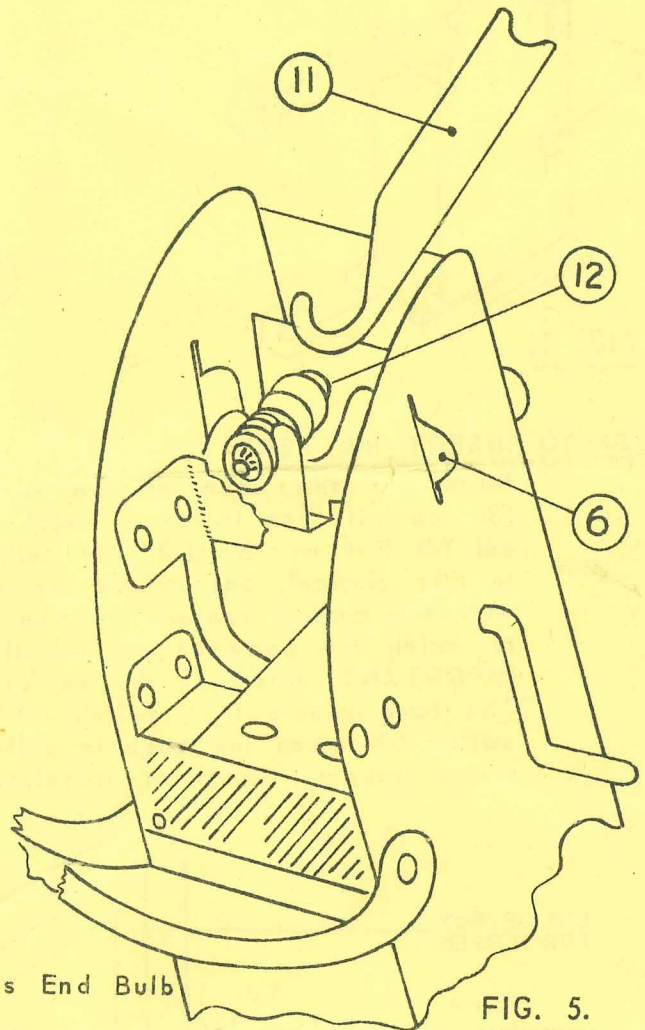

FIG. 5.

(G) NOTES

- Do NOT turn handle backwards.
- Do NOT pull film upwards.
- Do NOT bend the gate.
- Do NOT alter spring tension.

Use EVER READY Lens End Bulb
2.2 volt, No. 2225

Use two EVER READY type U.2. Batteries Leakproof.

(H) TO MAKE OR REPAIR A FILM LOOP

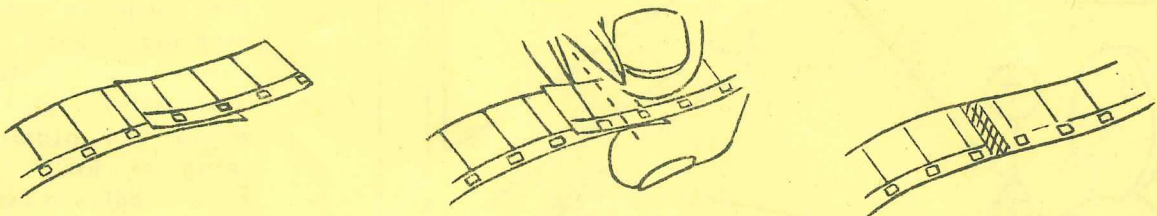

1. Take the two ends of the "Filmette" and overlap the first two pictures or "frames" with the last two pictures, so that the film holes lie EXACTLY on top of each other.

2. Holding the overlapping ends firmly cut with scissors through the double thickness of film. Make sure you cut only through the centre of a picture as illustrated.

3. When now examined you will see that the two ends of the film match up exactly. Now form your film loop by lining up the two cut ends together but NOT overlapping.

Seal with a Small piece of Sellotape on both sides - making sure that the film holes are NOT covered with Sellotape. Your loop is now ready for use.

IMPORTANT NOTICE: All "Filmettes" are specially treated for protection and long life by a chemical wax solution. If you find the film slips in the gate, rub the film between finger and thumb, this will remove excess wax.

All 8mm films are non-inflamable and completely safe.

In case of complaint this leaflet MUST be returned with the projector.